

HKN ECE 210 Exam 3 Review Session

Corey Snyder

Topics

- Fourier Transform
 - Signal Energy and Bandwidth
 - LTI System Response with Fourier Transform
 - Modulation, AM, Coherent Demodulation
 - Impulse Response and Convolution
 - Sampling and Analog Reconstruction
 - LTIC and BIBO Stability
- 

Fourier Transform

- The Fourier Transform of a signal shows the frequency content of that signal
 - In other words, we can see how much energy is contained at each frequency for that signal
 - ~~This is a big deal!~~
 - This is the biggest deal!

- $F(\omega) = \int_{-\infty}^{\infty} f(t)e^{-j\omega t} dt$
- $f(t) = \frac{1}{2\pi} \int_{-\infty}^{\infty} F(\omega)e^{j\omega t} d\omega$

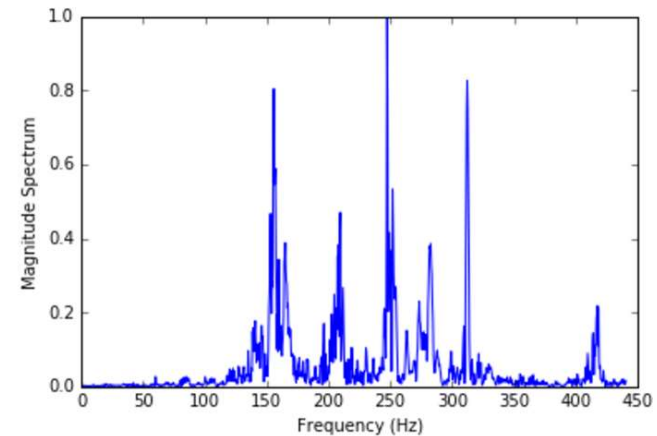
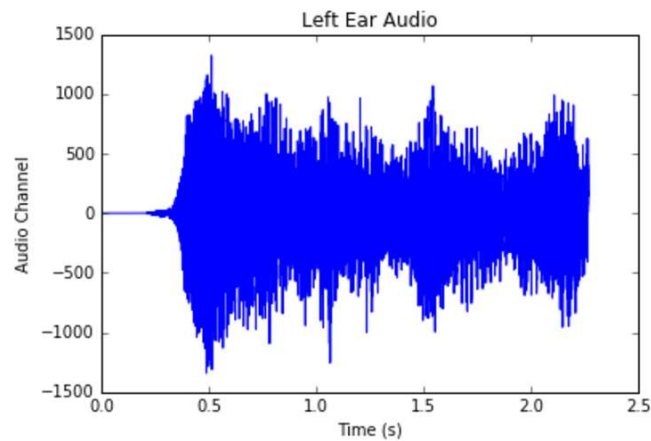

Important Signals for Fourier Transform

- $rect\left(\frac{t}{T}\right) = \begin{cases} 1, & \text{for } |t| < \frac{T}{2} \\ 0, & \text{for } |t| > \frac{T}{2} \end{cases}$
- $u(t) = \begin{cases} 0, & \text{for } t < 0 \\ 1, & \text{for } t > 0 \end{cases}$
- $\Delta\left(\frac{t}{T}\right) = \begin{cases} 1 + \frac{2t}{T}, & \text{for } \frac{-T}{2} < t < 0 \\ 1 - \frac{2t}{T}, & \text{for } 0 < t < \frac{T}{2} \end{cases}$
- $sinc(t) = \begin{cases} \frac{\sin(t)}{t}, & \text{for } t \neq 0 \\ 1, & \text{for } t = 0 \end{cases}$

Fourier Transform Tips

- Convolution in the time domain is multiplication in the frequency domain
 - $f(t) * g(t) \xleftrightarrow{\mathcal{F}} F(\omega)G(\omega)$
- Conversely, multiplication in the time domain is convolution in the frequency domain
 - $f(t)g(t) \xleftrightarrow{\mathcal{F}} \frac{1}{2\pi} F(\omega) * G(\omega)$
- Scaling your signal can force properties to appear; typically time delay
 - Ex: $e^{-2(t+1)}u(t-1) \rightarrow e^{-4}e^{-2(t-1)}u(t-1)$
- The properties really do matter! Take the time to acquaint yourself with them.
- Remember that the Fourier Transform is linear, so you can express a spectrum as the sum of easier spectra
 - Ex: Staircase function
- Magnitude Spectrum is even symmetric, Phase Spectrum is odd symmetric for real valued signals

Signal Energy and Bandwidth

- $Energy = W = \int_{-\infty}^{\infty} |f(t)|^2 dt = \frac{1}{2\pi} \int_{-\infty}^{\infty} |F(\omega)|^2 d\omega$
 - Energy signals can be either low-pass or band-pass signals
 - Why not high-pass?
- Bandwidth for Low-pass Signals
 - 3dB BW
 - $\frac{|F(\Omega)|^2}{|F(0)|^2} = \frac{1}{2}$
 - r% BW
 - $\frac{1}{2\pi} \int_{-\Omega}^{\Omega} |F(\omega)|^2 d\omega = rW$
- Bandwidth for Band-pass signals
 - r% BW
 - $\frac{1}{2\pi} \int_{\omega_l}^{\omega_u} |F(\omega)|^2 d\omega = \frac{rW}{2}, \Omega = \omega_u - \omega_l$

LTI System Response using Fourier Transform

- Given the following LTI system:

$$f(t) \rightarrow \boxed{H(\omega)} \rightarrow y(t)$$

- $Y(\omega) = F(\omega)H(\omega)$
- Computationally speaking, and in future courses, we prefer to use Fourier Transforms instead of convolution to evaluate an LTI system
- Why?
 - So much faster: $O(n \log n)$ vs. $O(n^2)$

Modulation, AM Radio, Coherent Demodulation

- Modulation Property
 - If $f(t) \leftrightarrow F(\omega)$, $f(t) \cos(\omega_o t) \leftrightarrow \frac{1}{2}[F(\omega - \omega_o) + F(\omega + \omega_o)]$
- In general, for Amplitude Modulation in communications, we modulate with cosine in order to shift our frequency spectrum into different frequency bands
- Coherent Demodulation refers to the process of modulating a signal in order to make it band-pass, then modulating it back to the original low-pass baseband before low-pass filtering in order to recover the original signal
- Envelope detection is the process of Full-wave Rectification (absolute value), then low-pass filtering in order to extract the signal

Impulse Response and Convolution

- Convolution
 - $x(t) * y(t) = \int_{-\infty}^{\infty} x(\tau)y(t - \tau)d\tau = \int_{-\infty}^{\infty} x(t - \tau)y(\tau)d\tau$
 - We “flip and shift” one signal and evaluate the integral of the product of the two signals at any value of t (our delay for the shift)
- Representing LTI Systems
 - $y(t) = x(t) * h(t)$, where $h(t)$ is the *impulse response* of the system
- Impulse Response is the system output to a $\delta(t)$ input
- Graphical convolution helps to visualize the process of flipping and shifting

Helpful Properties for Convolution

- Derivative
 - $h(t) * f(t) = y(t) \rightarrow \frac{d}{dt} h(t) * f(t) = h(t) * \frac{d}{dt} f(t) = \frac{d}{dt} y(t)$
 - Use of Derivative property: Finding the impulse response from the unit-step response
 - *If $y(t) = u(t) * h(t)$, then $\frac{d}{dt} y(t) = \frac{d}{dt} u(t) * h(t) = \delta(t) * h(t) = h(t)$*
- Start Point
 - If the two signals have start points at t_1 and t_2 , then the start point of their convolution will be at $t_1 + t_2$
- End Point
 - Similarly for the end points, if the two signals have end points at t_1 and t_2 , then the end point of their convolution will be at $t_1 + t_2$
- Width
 - From the above two properties, we can see that if the two signals have widths W_1 and W_2 , then the width of their convolution will be $W_1 + W_2$

The Impulse Function $\delta(t)$

- The impulse function is the limit of $\frac{1}{T} \text{rect}\left(\frac{t}{T}\right)$ as $T \rightarrow 0$
 - Infinitesimal Width
 - Infinite Height
 - Of course, it integrates to 1. ($0 * \infty = 1$)
- Sifting
 - $\int_a^b \delta(t - t_0) f(t) dt = \begin{cases} f(t_0), & t_0 \in [a, b] \\ 0, & \text{else} \end{cases}$
- Sampling
 - $f(t) \delta(t - t_0) = f(t_0) \delta(t - t_0)$
- Unit-step derivative
 - $\frac{du}{dt} = \delta(t)$

Sampling and Analog Reconstruction

- If we have an original analog signal $f(t)$
- Our digital samples of the signal are obtained through sampling property as:
 - $f[n] = f(nT)$ where T is our sampling period; this is Analog to Digital (A/D) conversion
- We must make sure to satisfy Nyquist Criterion:
 - $T < \frac{1}{2B}$ or $f_s > 2B$, $B = \text{Bandwidth}$ (in Hz)
 - To learn more about Nyquist Criterion and Sampling take ECE 110!

Sampling and Analog Reconstruction

- If we have an original analog signal $f(t)$
- Our digital samples of the signal are obtained through sampling property as:
 - $f[n] = f(nT)$ where T is our sampling period; this is Analog to Digital (A/D) conversion
- We must make sure to satisfy Nyquist Criterion:
 - $T < \frac{1}{2B}$ or $f_s > 2B$, $B = \text{Bandwidth}$ (in Hz)
 - To learn more about Nyquist Criterion and Sampling take ECE 110!
 - Just kidding, take ECE 310

Sampling and Analog Reconstruction

- If we have an original analog signal $f(t)$
- Our digital samples of the signal are obtained through sampling property as:
 - $f[n] = f(nT)$ where T is our sampling period; this is Analog to Digital (A/D) conversion
 - This results in infinitely many copies of the original signal's Fourier Transform spaced by $\frac{2\pi}{T}$
- We must make sure to satisfy Nyquist Criterion:
 - $T < \frac{1}{2B}$ or $f_s > 2B$, $B = \text{Bandwidth}$ (in Hz)
 - To learn more about Nyquist Criterion take ECE 110!
 - Just kidding, take ECE 310
- Following A/D conversion, we perform D/A conversion, then low-pass filter our signal in order to obtain our original signal according to the following relation
- $f(t) = \sum_n f_n \text{sinc}\left(\frac{\pi}{T}(t - nT)\right)$ 
- For a more complete explanation, take ECE 310!

Sampling and Analog Reconstruction (cont'd)

- The complete mathematical relationship between the continuous frequency spectrum and the discrete time (sampled) spectrum in analog frequency

$$F_s(\omega) = \frac{1}{T} \sum_{k=-\infty}^{\infty} F\left(\omega + \frac{2\pi k}{T}\right)$$

- The nuances of this representation will be explored and clarified in ECE 310!

BIBO Stability

- A system is BIBO stable if for any bounded input, we obtain a bounded output
- Two ways to check BIBO stability
- By the definition:
 - *If $|f(t)| \leq \alpha < \infty$, then $|y(t)| \leq \beta < \infty, \forall t$*
- By Absolute Integrability
 - $\int_{-\infty}^{\infty} |h(t)| dt < \infty$

LTIC

- LTIC stands for Linearity Time-Invariance and Causality
- Linearity
 - Satisfy Homogeneity and Additivity
 - Can be summarized by Superposition
 - If $x_1(t) \rightarrow y_1(t)$ and $x_2(t) \rightarrow y_2(t)$, then $ax_1(t) + bx_2(t) \rightarrow ay_1(t) + by_2(t)$
- Shift Invariance
 - If $x(t) \rightarrow y(t)$ then $x(t - t_0) \rightarrow y(t - t_0) \forall t_0$ and $x(t)$
- Causality
 - Output cannot depend on future input values

Problem 1 SP16

- Consider a real-valued function $f(t)$ with bandwidth Ω and let $\omega_c > \Omega$. Obtain the bandwidth of the following functions All answers may be left in terms of Ω and ω_c .
- (a) $g_1(t) = f(t) \sin(\omega_c t)$
- (b) $g_2(t) = f(t) + \sin(\omega_c t)$
- (c) $g_3(t) = f(t) \sin^2(\omega_c t)$
- (d) $g_4(t) = f^2(t) \sin(\omega_c t)$
- (e) $g_5(t) = f(t) * \sin(\omega_c t)$

Problem 3 FA16

- Given the circuit on the right:

(a) Find the step response

(b) Find the response to $x(t) = \text{rect}\left(\frac{t-1}{2}\right)$

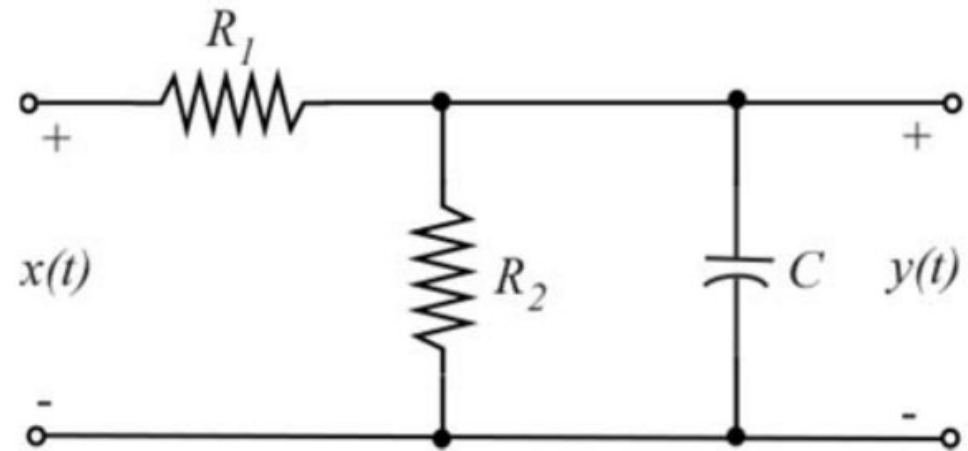

Problem 3 SP14

(a) An impulse response is given by

$$h(t) = \text{rect}\left(\frac{t-1}{2}\right)e^{-t}$$

- i) Find the Fourier transform of $h(t)$.
- ii) If the input is $f(t) = 2\text{rect}\left(\frac{t}{2}\right)$, find the output $y(t) = f(t) * h(t)$.
- iii) If the input is $f(t) = \frac{1}{a}\text{rect}(at)$, find the output $y(t) = f(t) * h(t)$, when $a \rightarrow 0$.

Problem 2 SP13

(a) For $h(t)$ and $f(t)$ shown below, compute the specified values for $y(t) = f(t) * h(t)$

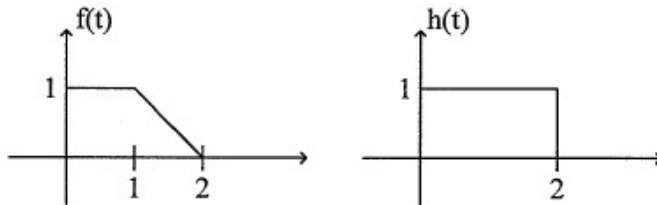

$$y(-0.5) = \underline{\hspace{2cm}}$$

$$y(0.5) = \underline{\hspace{2cm}}$$

$$y(1.5) = \underline{\hspace{2cm}}$$

$$y(2.5) = \underline{\hspace{2cm}}$$

$$y(3.5) = \underline{\hspace{2cm}}$$

$$y(4.5) = \underline{\hspace{2cm}}$$

(b) Let $h(t) = e^{-2t}u(t)$ and $f(t) = u(t - 4)$. Find $y(t) = f(t) * h(t)$ for all values of t .

Problem 2 FA15

Consider the following system

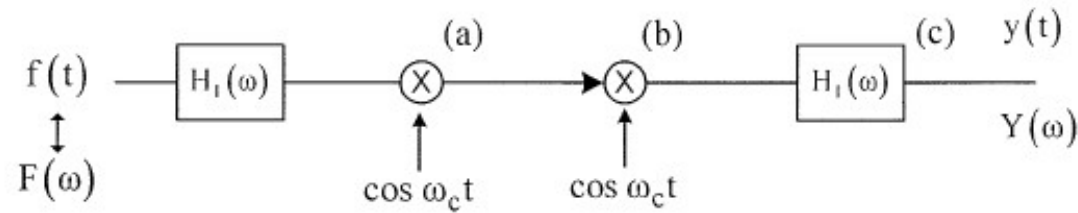

where $f(t) = \text{rect}(\frac{t}{\tau})$, $\tau = 10^{-3}$ sec, $\omega_c = 2\pi 10^6$ rad/sec and

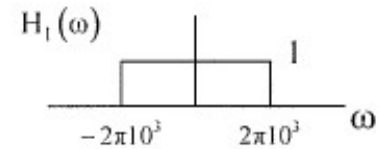

a) What is $F(\omega)$? Label axis carefully.

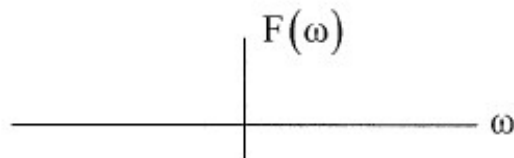

$F(\omega) =$ _____ (5 points)

b) Draw the signal spectrum at points, (a), (b) and (c). Label axis carefully.

Problem 4 SP14

i) Consider this sampling/reconstruction system.

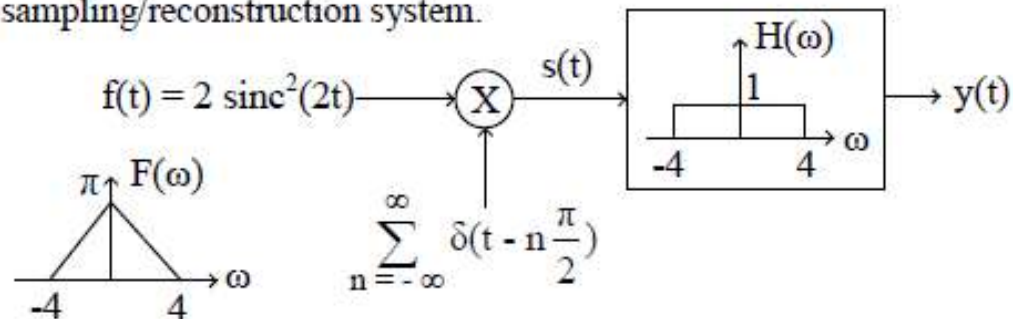

i) Circle the correct answer and explain it below.

$f(t)$ is: **UNDERSAMPLED** / **OVERSAMPLED** / **SAMPLED AT NYQUIST RATE**

Explanation:

ii) Sketch $S(\omega)$ and $Y(\omega)$ on the axes below.

iii) Determine $y(t)$

Problem 5 FA13

5. (8 pts) The two parts of this problem deal with impulse response, causality and BIBO stability.

(a) (4 pts) The figure below depicts a LTI system. Input signal $f(t)$ produces the corresponding output $y(t)$.

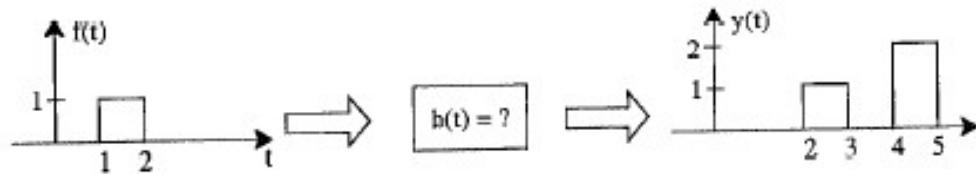

(b) (4 pts) The figure below depicts a LTI system. Input signal $f(t)$ produces the corresponding output $y(t)$.

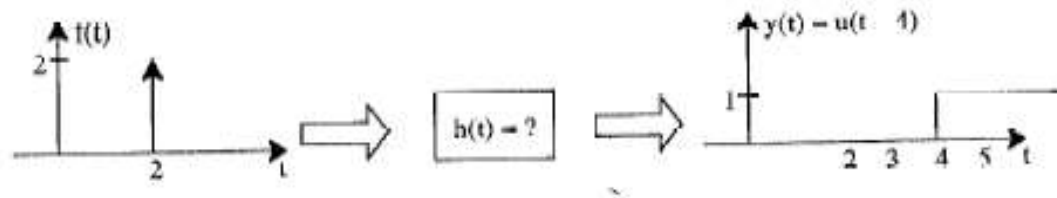

- a)i. Determine $h(t)$
- ii. Is the system causal?
- iii. Is the system BIBO stable?
- b)i. Determine $h(t)$
- ii. Is the system causal?
- iii. Is the system BIBO stable?